

# StrapPack<sup>®</sup>

Automatic Strapping Machine



**RQ-8x**

# RQ-8x



## The Evolution of the Market-leading RQ-8 Series

The RQ-8x is the evolution of one of StraPack's most popular and longest selling models, the RQ-8. The new RQ-8x offers a higher strapping speed along with the same reliability, intuitive operation and ease of maintenance that the market has come to expect. These features reinforce the market leading position of the RQ-8 series machines.

### ■ High Speed

Up to 55 straps per minute (even with tension applied).

### ■ Anti-Jam Function

If the RQ-8x is operated accidentally without a package in place, the strap will form a loop, leaving the machine ready for the next cycle.

### ■ Easy Strap Loading

Strap loading is as easy as a touch of a lever. There is no need to thread the strap.

### ■ Automatic Re-feed

In case of a feeding issue, the machine will re-feed the strap automatically.

### ■ Easy Maintenance

Self-lubricating design reduces wear and tear and increases operational life.

### ■ Advanced Heater Design

RQ-8x is ready to operate in less than 25 seconds, contributing to increased packaging line efficiencies.

### ■ Portable

Heavy-duty metal casters allow the RQ-8x to be quickly moved to any single phase power supply outlet.

### ■ Variable Tension

A wide range of tension is available via a digitally controlled tension dial. Tension capability is up to 80kgf or 176lbs (equivalent of 150mm or 6" stroke). Unlike many other machines in the market, tension does not compromise the cycle speed.

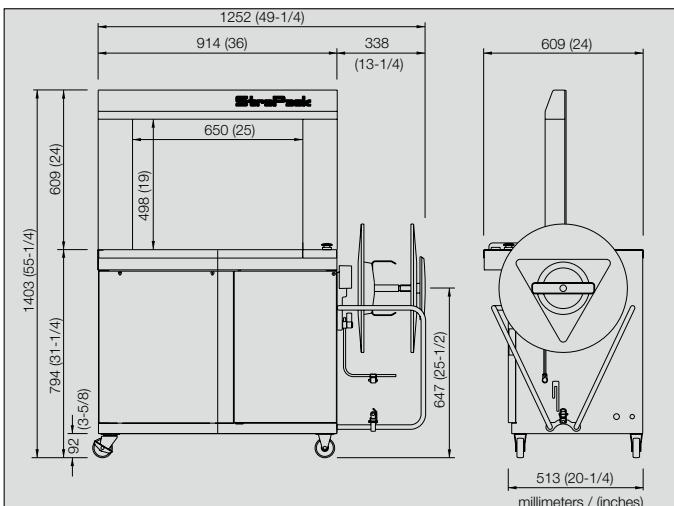

Specifications of Standard Arch Size (650 mm wide x 500 mm high or 25" wide x 20" high)

Dimension	Width	1252 mm	49-1/4 in.
	Height	1403 mm	55-1/4 in.
	Depth	609 mm	24 in.
	Weight	160 kg	353 lbs.
Table Height		794 mm	31-1/4 in.
Package Size	Max	W 620 X H 480 mm	W 24-1/2 X H 18-7/8 in.
	Min	W 80 X H 30 mm	W 3-1/8 X H 1-1/4 in.
Joint / Strap/ Coil		heat seal / polypropylene ID 200 X OD 450 X W 200 mm	heat seal / polypropylene ID 8 X OD 18 X W 8 in.
Strap Width		5, 6, 9, 12, (15.5) mm	5mm, 1/4, 3/8, 1/2, (5/8) in.
Power Supply		100, 120, 200, 220, 230, 240V single phase 50 / 60Hz 0.9KVA	

Dimensions and specifications are subject to change without notice.

Modification rights reserved.

Pats., U.M. & design registered and/or pending.

© 2012 Strapack Corporation

### DISTRIBUTED BY:

#### STRAPACK CORPORATION

7-16-14, Ginza, Chuo-ku Tokyo 104-0061, JAPAN  
Phone 81-3-6278-1805 Fax. 81-3-6278-1806  
(URL) <http://www.strapack.com> (E-mail) [info@strapack.com](mailto:info@strapack.com)

#### STRAPACK INC.

30860 San Clemente St. Hayward, CA 94544 U.S.A.  
Phone 1-510-475-6000 Fax. 1-510-475-6090

#### STRAPACK, N.V./S.A.

Uilenbaan 200, 2160 Wommelgen, BELGIUM  
Phone 32-3-355-1520 Fax. 32-3-355-1521